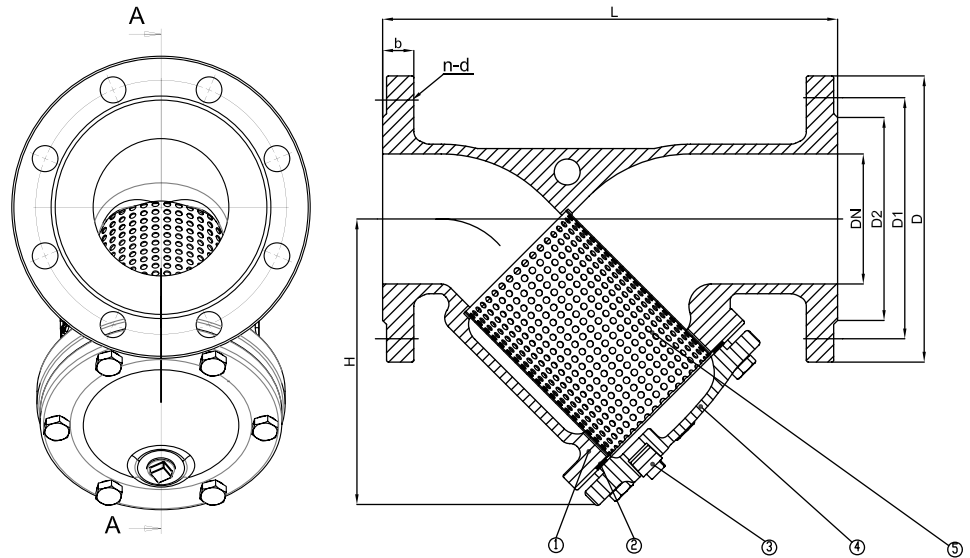

Fig. S101F



DIN/BS Y strainer



Features

- Y-Pattern
- Stainless Steel Screen
- Bolted Cover
- Flanged Ends
- FBE Coated
- Product color: Blue, RAL 5017

Technical Specification

- Face to Face : DIN3202 F1
- Flanges: EN 1092-2 PN16
- Hydraulic test to ISO 5208
- Shell Test Pressure: 24 bar

Artwork on valve body:

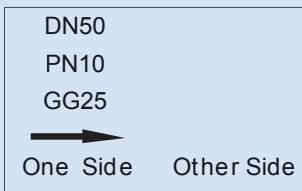

▲ MATERIAL SPECIFICATION

Item	Part Name	Material	Item	Part Name	Material
1	Body	GG25 /GGG50	5	Bolt&nut	Galvanized flat head bolt
2	Cover Gasket	Graphite With Soft Steel			Galvanized stud bolt
		EPDM/NBR			Stainless Steel
3	Cover	GG25 /GGG50	6	Screen	SS Wire Screen
4	Plug	Zinc Steel BSPT			SS Perforated Mesh

▲ DIMENSIONS(mm)

Size	L	D	D1	D2	b	n-d	H	Plug	W.T(kg )
DN15	130	95	65	46	14	4-14	65	1/4"	2.0
DN20	150	105	75	56	16	4-14	70	1/4"	2.3
DN25	160	115	85	65	16	4-14	80	1/4"	3.2
DN32	180	140	100	76	18	4-19	90	1/4"	5.0
DN40	200	150	110	84	18	4-19	135	1/2"	6.5
DN50	230	165	125	99	20	4-19	150	1/2"	8.7
DN65	290	185	145	118	20	4-19	160	1/2"	12.0
DN80	310	200	160	132	22	8-19	200	1/2"	19.0
DN100	350	220	180	156	24	8-19	240	1/2"	27.0
DN125	400	250	210	184	26	8-19	290	3/4"	40.0
DN150	480	285	240	211	26	8-23	330	3/4"	58.0
DN200	600	340	295	266	30	12-23	380	3/4"	86.0
DN250	730	405	355	319	32	12-28	480	1"	127.0
DN300	850	460	410	370	32	12-28	550	1"	200.0
DN350	980	520	470	429	36	16-28	680	2"	320.0
DN400	1100	580	525	480	38	16-31	780	2"	420.0
DN450	1200	640	585	548	40	20-31	830	2"	620.0
DN500	1250	715	650	609	42	20-34	910	2"	780.0